

Seminar

Restbiomasse fra landbrug og naturarealer til biogasproduktion

Processbio A/S

Processbio og partnere har mere end 25 års erfaring indenfor håndtering af biomasse sektoren.

Processbio leverer og installerer komplette fuldskala “front-end” materiale håndtering- og pre-proces systemer til håndtering af biomasser i både balle og bulk form.

Applikationer

Automatisk materiale håndtering og pre-proces løsninger af biomasse i både balle- og bulk form:

- 100% Biomasse fyrede kraftværker
- Tilsatsfyrede kraftværker
- 2. generation bio-ethanol værker
- Halm og træpille værker
- Biomasse fyrede procesdamp kedler
- Biogas anlæg

Vores ekspertise

- Turn key løsninger
- Komplet leverance af udstyr
- Projekt styring
- System design
- Performance garantier
- Real time computer simuleringer

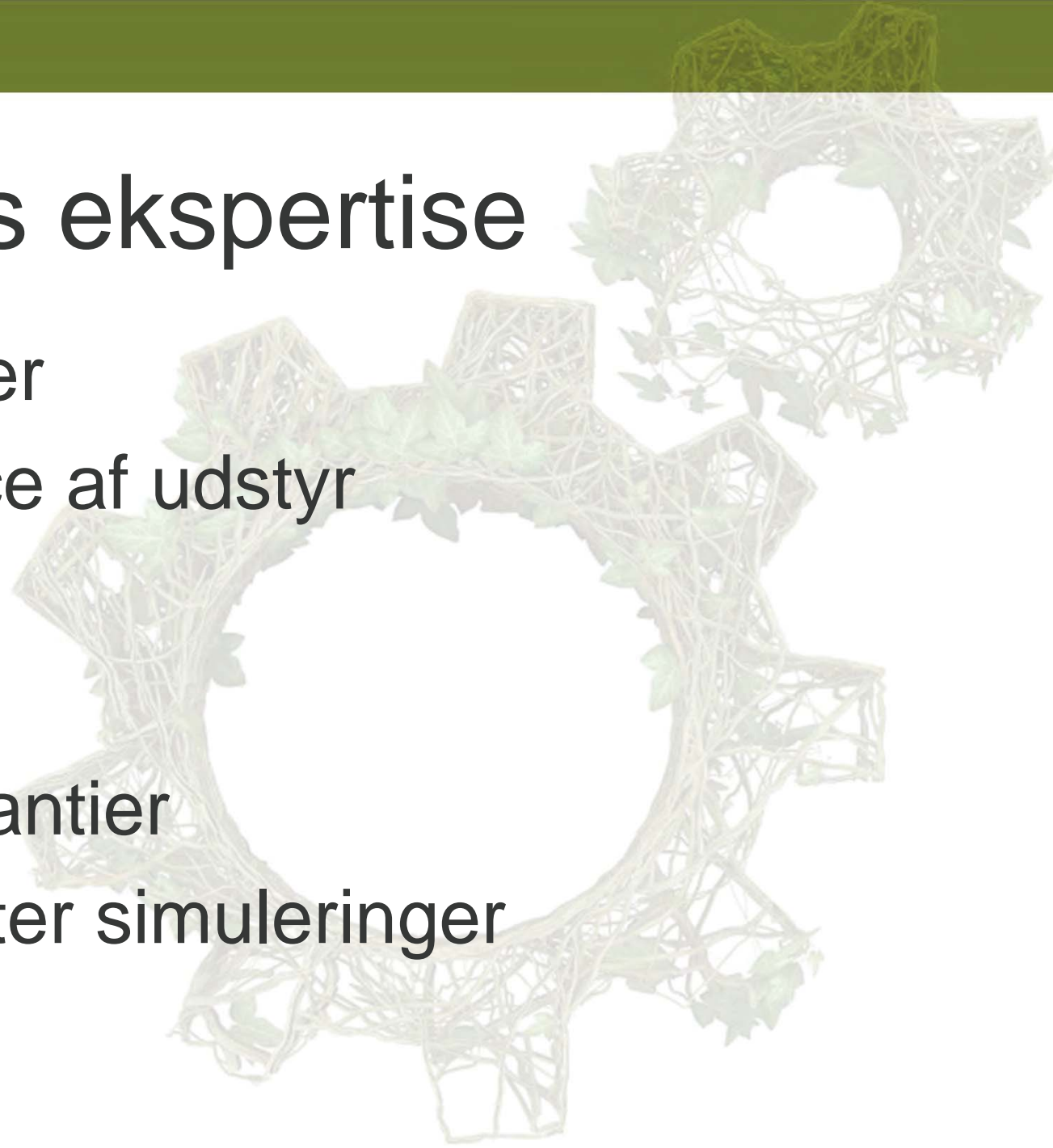

Biomasse registrering

- Registrering af biomasse ved ankomst til værk (RFID kort)
- Vejning (kommerciel godkendte vejemoduler)
- Fugtighedsmåling til baller (mikrobølge baseret)
- Lagerstyrings system – IntraLog System
- Data kommunikation med værkets ERP system
- Afregningskalkulation til leverandører.



Fugtighedsmåling

3-spots målinger monteret i griber på kran



1-spot in-line måling



Robot kraner til håndtering af baller



Hydraulisk drevne griber



Kædebaner

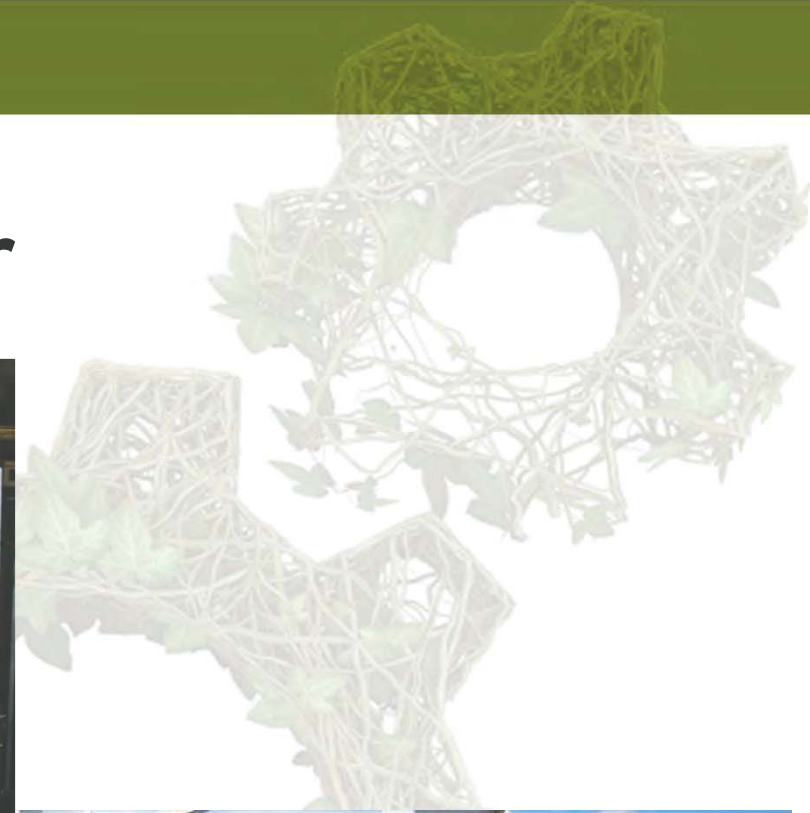

Distributionsenhed til baller

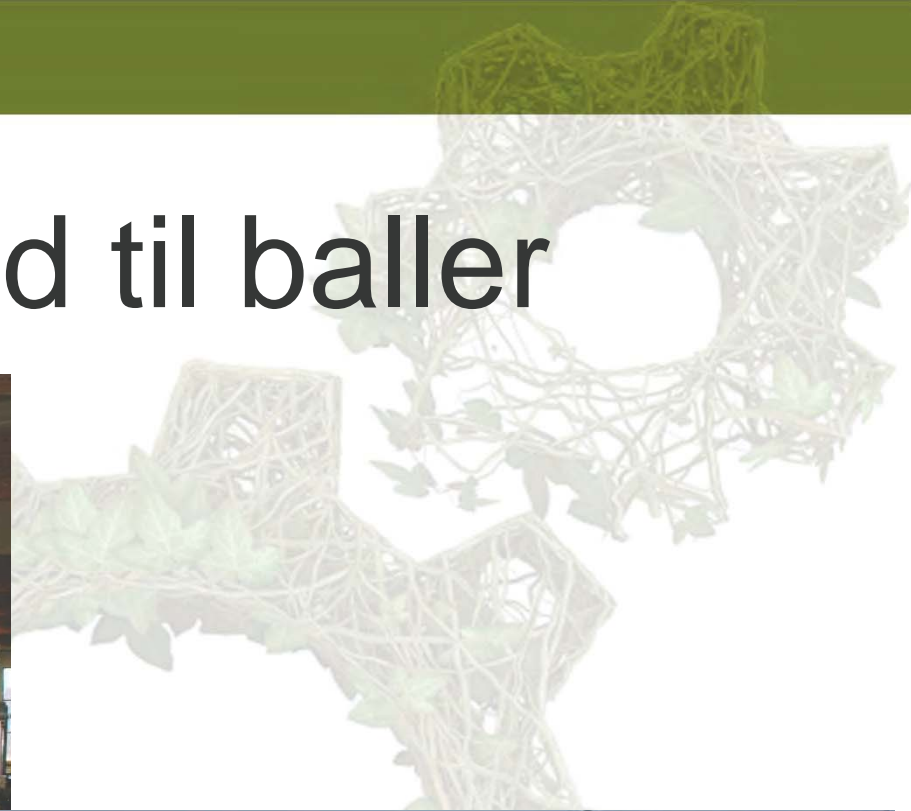

Snoreskærere og -aftager

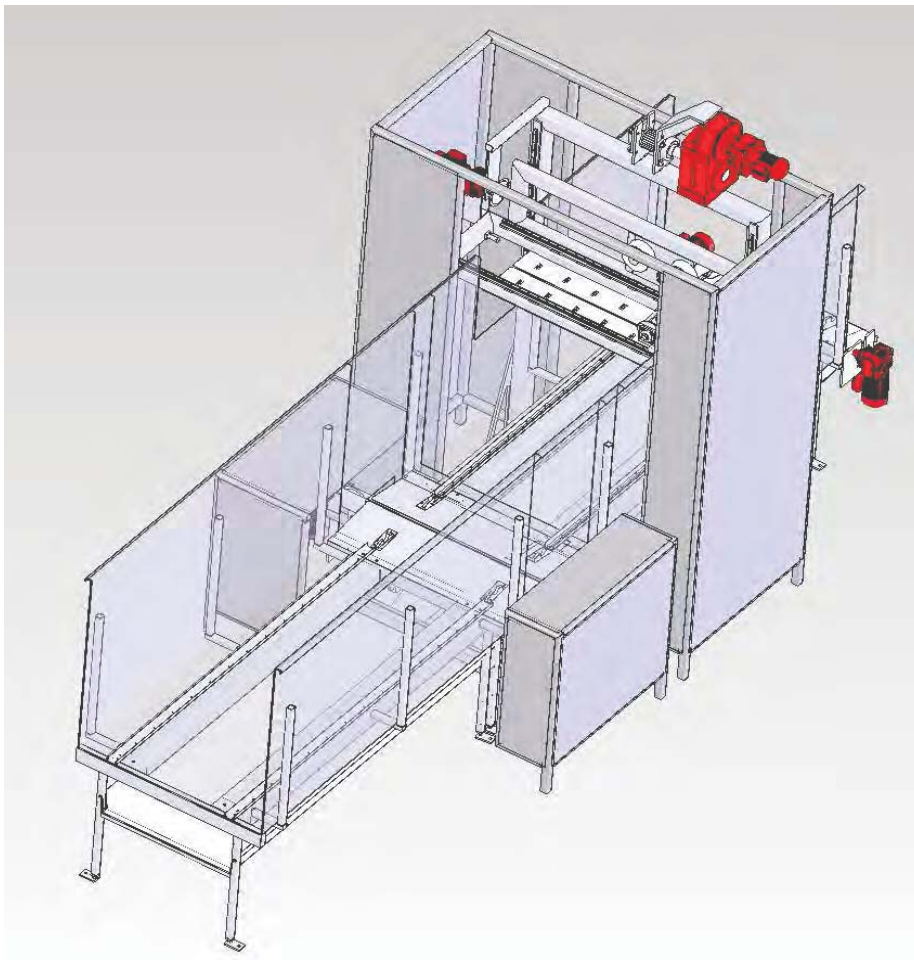

Robotkran til bulk materiale



Kombinerede hopper



Transportører til bulk materiale



Skrue/snegle transportør

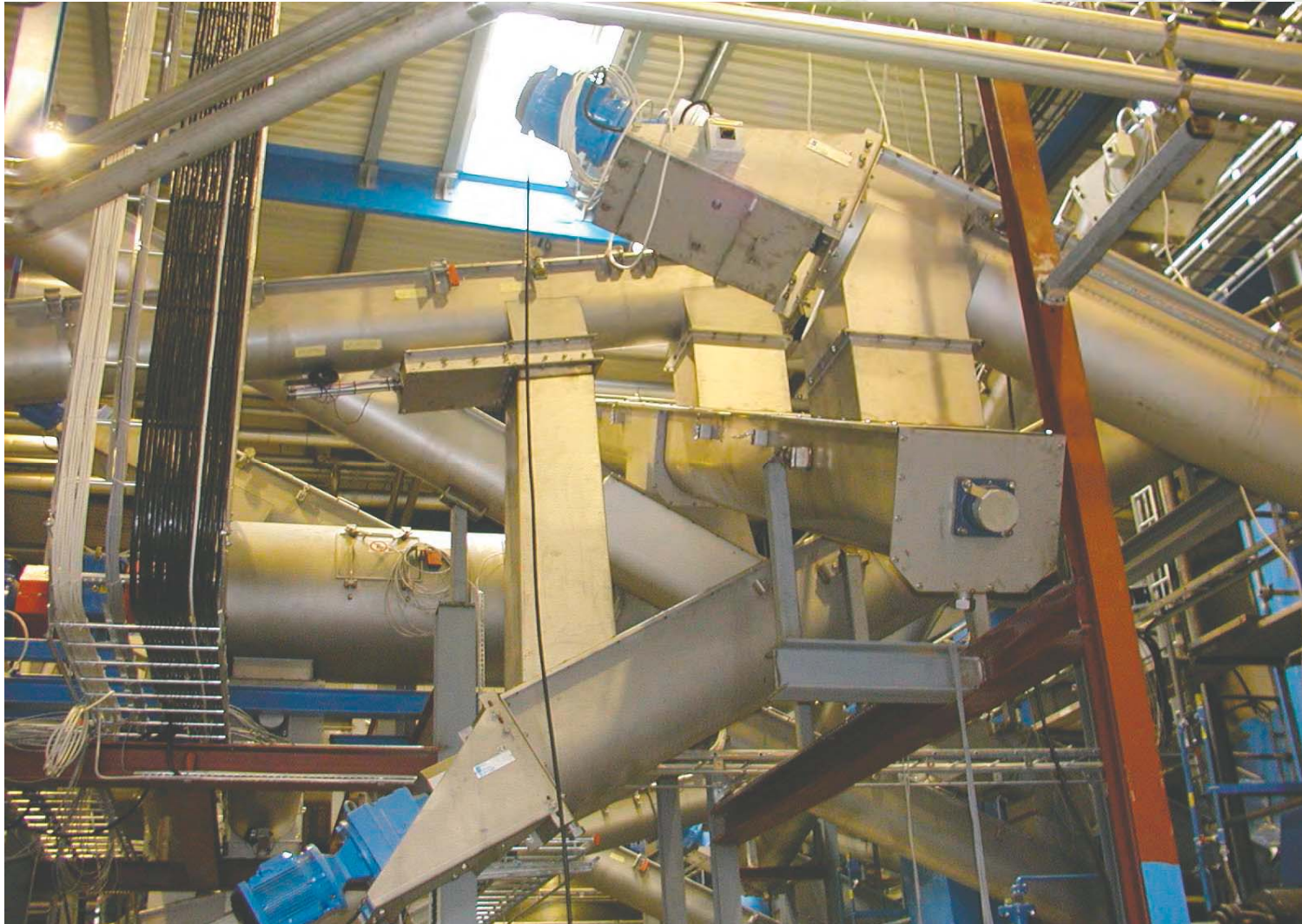

Rørtransportør

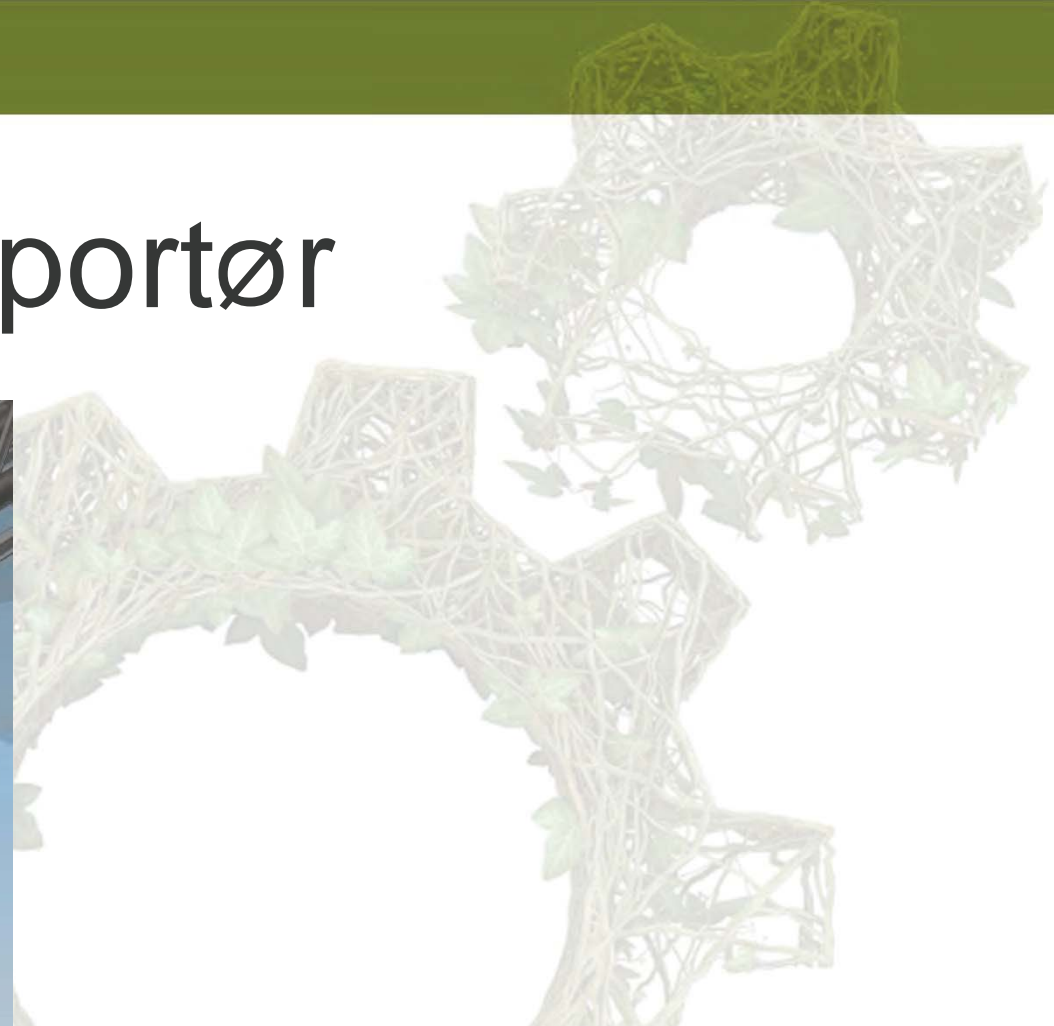
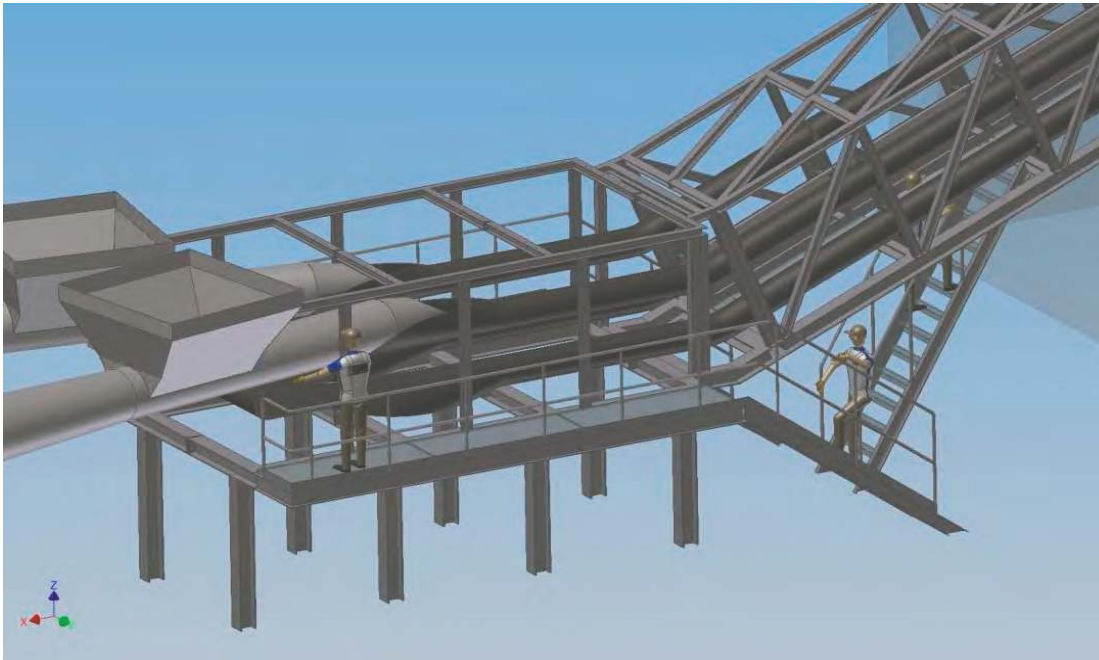

Opriver til baller



Biomasse dosering, rensning, sten fælter



Stratek Multi shredder MS-300 - Straw mill HM-770 - stone trap
Stratek Multi Zerreisser MS-200 - Strohühle HM-770 - Steinfalle

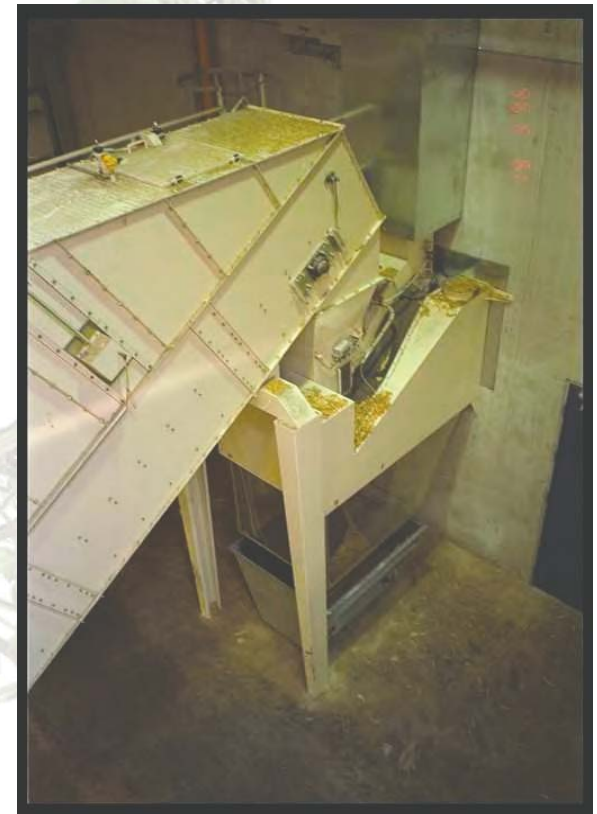

Biomasse rensning – metal screener



Biomasse rensning – disc screener

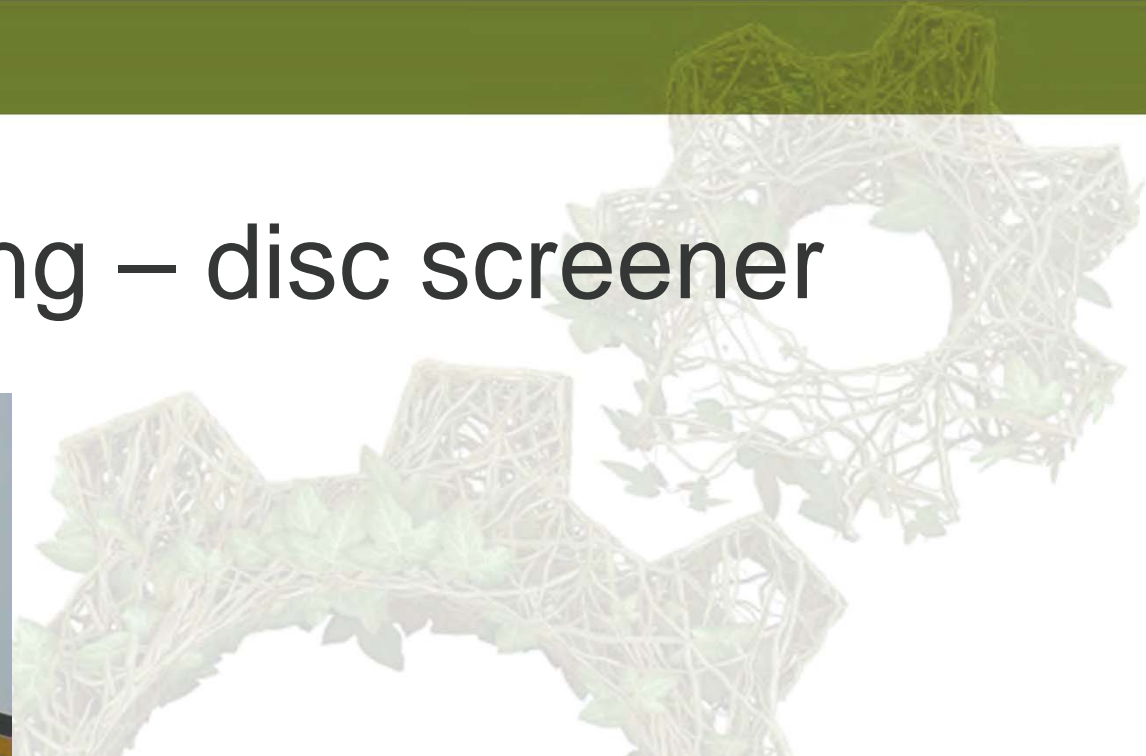

Støvfilter og cykloner



Stratek straw silo HS-15 - filter JM52-30
Stratek Strohsilo HS-15 - Filter JM52-30



Hammer møller & ventilatorer



Kontrol sistem

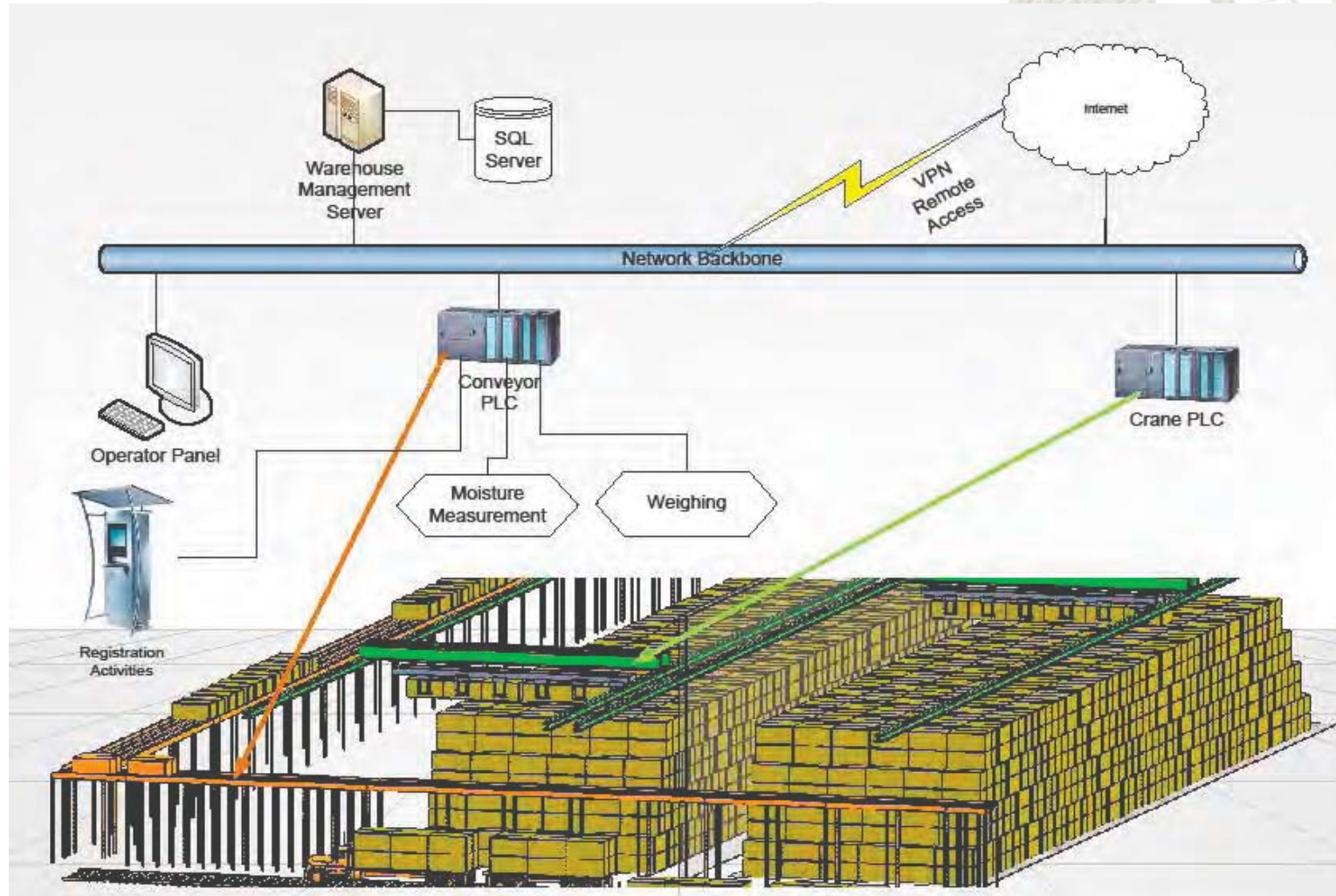

Selv diagnosticerings system

SCADA
9:41 AM

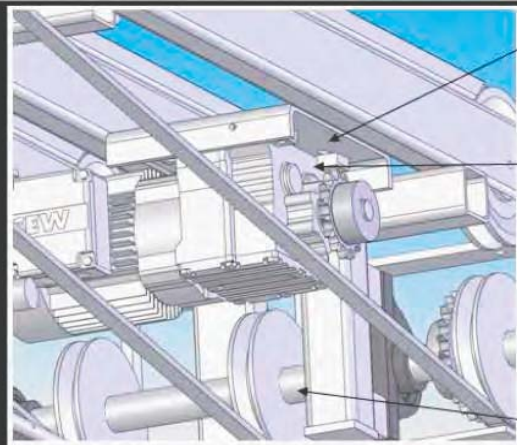

Motor plate

Drive shaft

Adjustment/tightening of drive chain is done by loosening the screws attaching the gear to the motor plate and move the gear motor away from the drive shaft.
NB: The gear motor must be placed parallel to the drive shaft!

Service

Service Needed on Belt Conveyor

Item: 555.001
Cycles: 87258 / 60000

LUBRICATION:

Component	Execution / Lubricant
Chains	Klüberoil 4 UH 1-460N
Gear motor	Life time lubricated

MAINTENANCE:

Component	Condition	Action
Drive chain	Slack	Adjustment
Cylinder	Leakage, noise	Replacement
Valves	Leakage, noise	Replacement
Belts	Worn out	Replacement
Belts	Loose	Tightening

Verification Key: 37681

Perform service

02A. SLITTER 54

Adjust Drive Chain







Tak for opmærksomheden

For yderligere information:

Processbio A/S

Allan Thysen

at@processbio.com

M: +45 2326 1667

